

CrashGuard⁺ CG421

mic isolator for Sennheiser[®] MD 421

USER GUIDE

Thank you and congratulations on purchasing the Primacoustic CrashGuard™ CG421! Please take a few minutes to read through this manual. The CG421 is designed to surround a Sennheiser[®] MD421 microphone on three sides to attenuate the sound of nearby cymbals or hi-hat during the recording process. This attenuation allows the engineer to capture the drum sound without having too much extra sound bleeding into the recording. Please refer to www.primacoustic.com for various placement options, benefits, and general information. Should you have any questions or comments, we invite you to send us an email at info@primacoustic.com.



Mounting Position A:

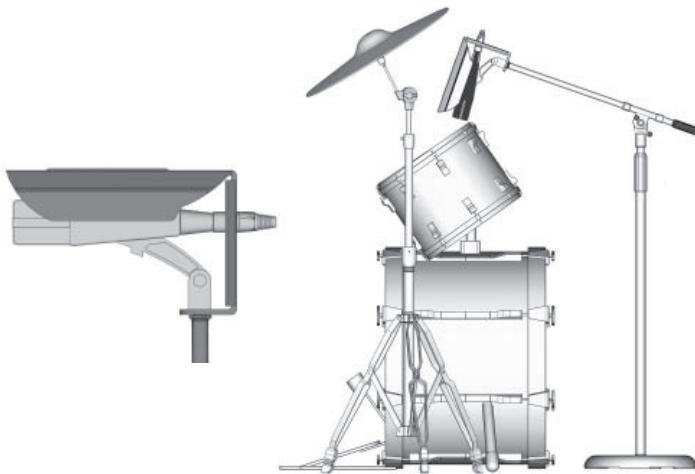

The CG421 is designed to fit any standard boom arm. Begin by taking the mic clip off your mic stand boom arm. Make sure you leave the knurled ring on that usually comes with most booms. The CG421 comes equipped with a spare ring in case you do not have one. Push the CG421 onto the boom arm then screw the mic clip onto the boom. Do not over tighten. Connect the mic by passing the cable through the rear access port. The mic may be articulated up and down. Leave some space between the mic head (capsule) and the inside of the CG421. This will reduce any effect the shell may have on the mic's polar pattern.

Mounting Position B:

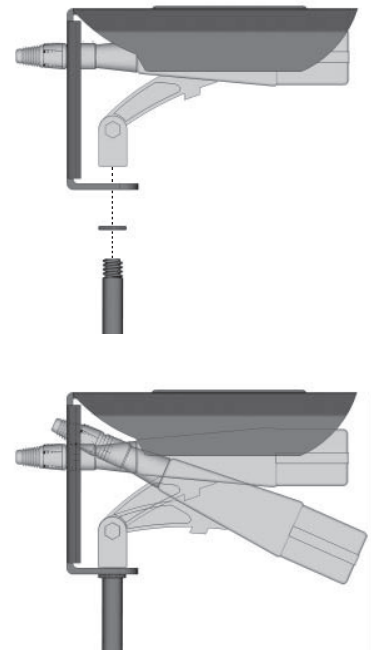

WARRANTY

Please inspect products immediately after receiving your purchase. Primacoustic acoustic products are guaranteed to be free of manufacturing defects for a period of 3 years after purchase. In the unlikely event that a defect is uncovered, please call 604-942-1001 to obtain a RA number (Return Authorization number) from Primacoustic before the 3 year warranty period expires. Once you have obtained a RA number you must return the product, freight prepaid, within fifteen (15) days after the date the RA number is issued. Please return the product in the original packaging (or another, affording an equal degree of protection) with all of the following: (1) RA number clearly marked on the returned package; (2) a receipt or bill of sale showing proof of purchase from an authorized seller; plus (3) a letter describing the defect. Please include your name, address, telephone number and the applicable RA number. You are solely responsible for all shipping and insurance costs for returning the product to Primacoustic, and you will not be reimbursed or compensated for any loss or damage incurred during return shipping. Primacoustic will at its sole discretion repair or replace the product. Should the product no longer be available, Primacoustic reserves the right to exchange this with a product of similar performance and value. Due to different dye lots, Primacoustic cannot guarantee exact color match. This Warranty shall solely extend to the original owner and is limited to manufacturing defects and excludes damage due to improper installation, freight handling, wear and tear, abuse, misuse, misapplication, color fading or deterioration due to prolonged exposure to ultra violet light, smoke, humidity or other environmental factors. It is understood that the use and suitability of the product is entirely the responsibility of the buyer or specifying engineer and as such, these parties agree to hold Primacoustic, or its associated company, and/or officers, harmless from any responsibility whatsoever other than what is clearly outlined in this warranty.